

SURF LIFESTYLE ADVENTURE

 **Northcore**



**SURF**

**Uncompromising  
products that are  
proven essentials**

<b>3</b>	<b>BRAND STORY</b>
<b>19</b>	<b>NORTHCORE TEAM RIDERS</b>
<b>25</b>	<b>LOOK BOOK</b>
<b>31</b>	<b>THE COLLECTION</b>
<b>39</b>	<b>BRAND GUIDELINES</b>
<b>47</b>	<b>RETAIL TOOLKIT</b>

**ADVENTURE**



## BRAND STORY

An aerial photograph of a coastal scene. On the left, a massive, layered cliff face of golden-brown rock rises vertically. At its base is a wide, sandy beach. In the center of the beach, three people are standing with their surfboards. To the right, the ocean meets the shore with waves breaking over dark, jagged rocks. The water is a deep blue-green, and the white foam of the waves is visible. The overall lighting is bright, suggesting a sunny day.

**Born from**

**the elements**



**Built for** necessity











OUR ROOTS ARE IN  
HARDCORE COLD  
WATER SURFING AND  
ADVENTURE SPORTS.

SO WE KNOW WHAT IT  
TAKES TO GET OUT THERE.  
IN BOTH ATTITUDE AND THE  
GEAR THAT'S ESSENTIAL.





THIS ISN'T FOR THE FAINT OF HEART

OR THE FAIR WEATHERED





# Born from the ocean

I have always believed that we spend all our time on this planet but hardly any engaging with it. It's out of this belief that Northcore was born, to enable surfers and explorers of all levels to have the maximum amount of exposure to the wildest of waters on this amazing planet. Because if you don't have a where, you don't have a why.

**Keeping you out there,  
where you belong,**

**connected with the wild.**



ON  
THE  
WAVE

IN  
THE  
WILD











**NORTHCORE TEAM RIDERS**

**To most, being  
relentlessly  
lashed with  
freezing spray  
would be sheer  
misery. To us,  
it's pure magic.**



**I broke three  
boards in one  
morning at  
Rocky Point;  
it was that big.**

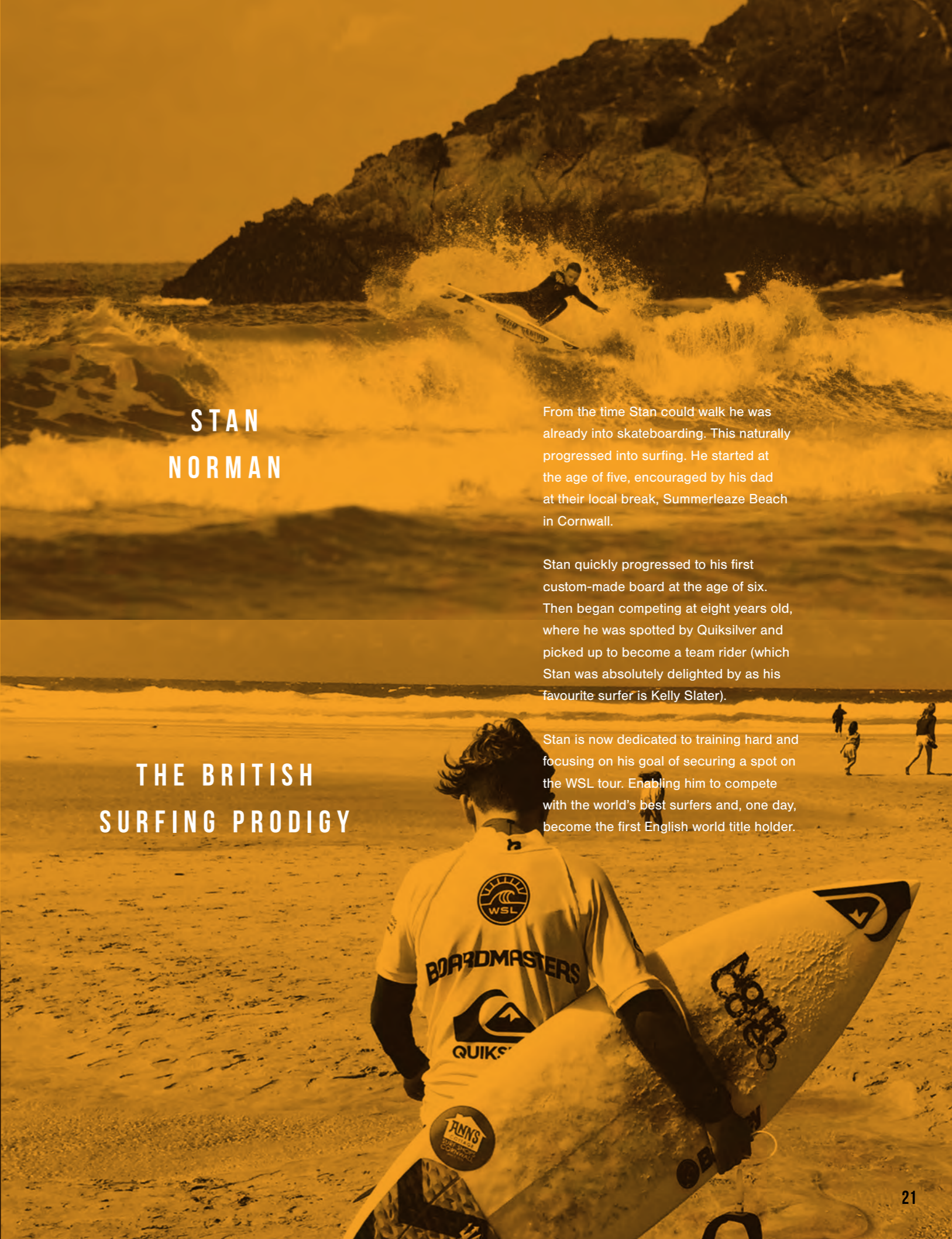

**STAN  
NORMAN**

From the time Stan could walk he was already into skateboarding. This naturally progressed into surfing. He started at the age of five, encouraged by his dad at their local break, Summerlease Beach in Cornwall.

Stan quickly progressed to his first custom-made board at the age of six. Then began competing at eight years old, where he was spotted by Quiksilver and picked up to become a team rider (which Stan was absolutely delighted by as his favourite surfer is Kelly Slater).

**THE BRITISH  
SURFING PRODIGY**

Stan is now dedicated to training hard and focusing on his goal of securing a spot on the WSL tour. Enabling him to compete with the world's best surfers and, one day, become the first English world title holder.



**I'M NOT GOING SURFING.  
I'M GOING INTO BATTLE.**

**PETER CONROY**  
**THE GRAFTER**

Peter admits he wasn't always the best surfer back in the day. But he could always count on abilities developed through rigorous fitness regimes, which certainly help when taking a beating from a big wave.

Over the years he's honed his skills and now feels very comfortable surfing and rescuing in anything over 20ft. Peter works full-time as a fireman/paramedic in the Dublin Fire Brigade. When he's not working he drives all over the country surfing. As he says, "I work to surf... for the love of surfing..."





Sandy Kerr was born and raised on the UK's North East coast, overlooking the sea and the Tyne River mouth. Surfing doesn't get much more real than in the North Sea, where you'll share the cold water, heavy waves, barrelling reefs and sand bars with a core crew of dedicated surfers.

Sandy began to surf at the age of 14, alongside some of the UK's finest ever riders, including the Davies Brothers, Sam Lamiroy and Joel Gray. Sandy rips on all of the local waves from The Cove in North Yorkshire up to Northumberland and beyond to Thurso on Scotland's North Shore when it's firing.

Sandy continues to push himself further into bigger and heavier waves, including winter trips to Oahu and Ireland, as well as entering surf competitions when the opportunity arises. Sandy's progression has also been helped by having Gabe Davies as his wingman, offering invaluable inspiration and encouragement. During the summer months, Sandy works as a surf instructor and lifeguard on his local beaches, while down time includes coffee drinking, bodysurfing and free diving.

## SANDY KERR

## THE NEXT GENERATION

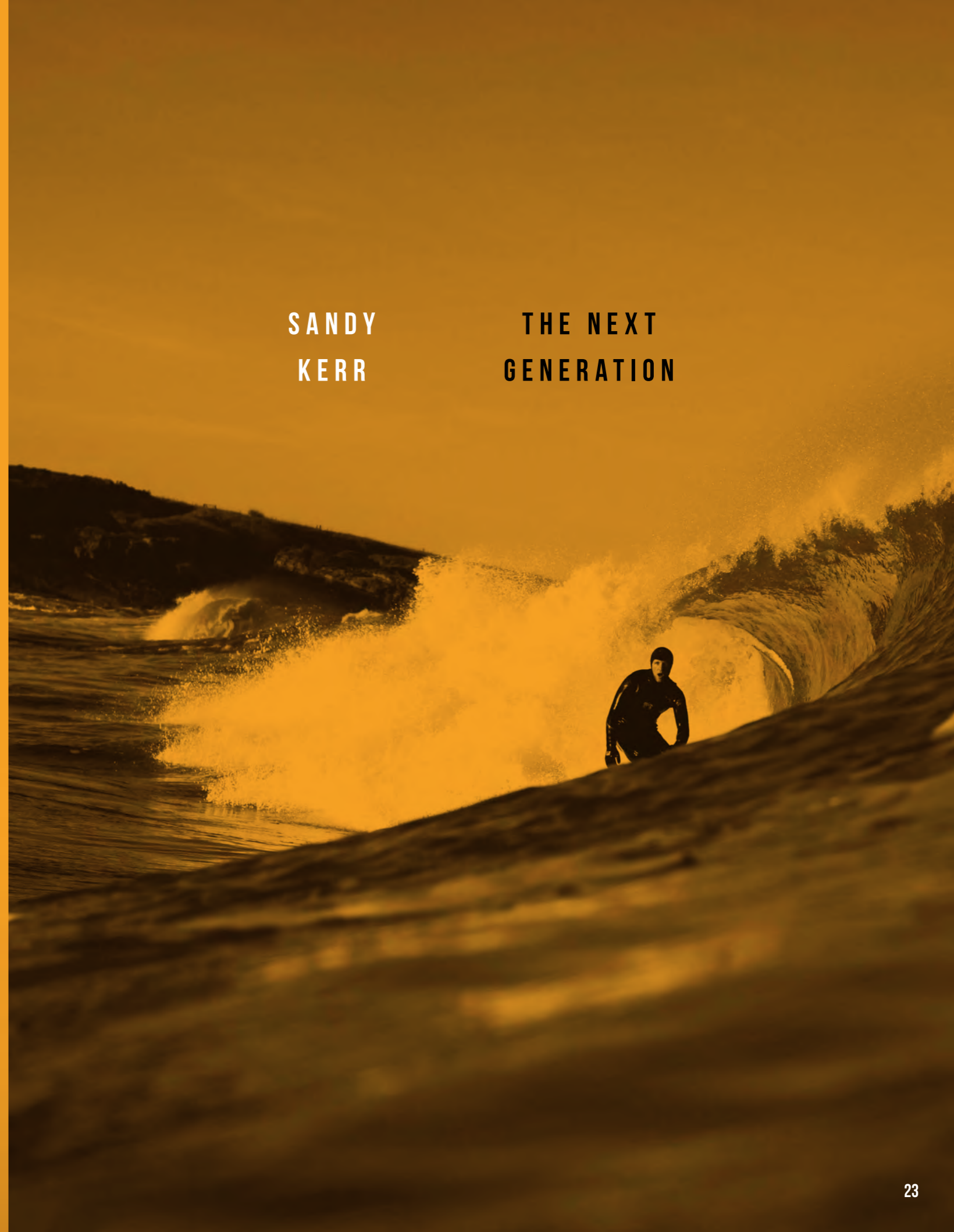



Lucie has lived in Cornwall all her life. Being surrounded by so many beautiful beaches and coastlines it seemed like a natural progression for her to start surfing. In her early teens she was an active competitor in all the major UK surf competitions, but found she performed better when she was 'free' surfing. A fact that drove her to surf whenever she could, whatever the conditions, to improve her performance.

Lucie is now a freelance ISA Surf Instructor, teaching at some of the best surf schools in her home town of Newquay. She's also been made an Ambassador of the Wave Project and regularly volunteers with them to help teach children with disabilities improve their confidence through learning to surf.

With a keen desire to still be involved in the competitive world of surfing, Lucie recently qualified as an ISA accredited Surf Judge. Enabling her to work closely with surfing GB and the UK Pro Surf Tour, judging and interviewing some of Britain's top surfers.

In her spare time, Lucie is continually promoting her love of surfing through her social media pages and has secured the backing and support of some major surf brands, including Northcore. As well as exploring further opportunities within the surfing industry, Lucie is continuing her professional modelling career.

LUCIE  
DONLAN

SOUL  
SURFER





**When you're  
up there, riding  
a mountain of  
water, nothing  
comes close.**

**LOOK BOOK**

**Much like  
our riders,  
our products  
also have a  
story to tell.**



United Kingdom.  
Northcore Waxed canvas backpack.

The Northcore Roll-top backpack is a simple,  
classic day bag produced in a heavy duty waxed  
cotton canvas.



Sally McGee.  
Panama.  
Northcore Board Bag.

Tynemouth surfer, teacher and adventurer,  
Sally McGee spent a year on the road in the  
Americas, crossing the continent on a dirt bike.

Tom Bing.  
Chile.  
Northcore Trucker Cap.

UK-based surfer, photographer and adventurer,  
Tom Bing spent a year travelling the length of the  
Pan-American Highway with his wife, Sally McGee.



Scott Dickerson.  
Alaska, USA.  
Northcore 40L Dry Bag.

Alaska-based photographer Scott Dickerson regularly explores the Pacific Aleutian Islands for surf on a re-fitted fishing boat.

Corinne Evans.  
Cornwall, UK.  
Northcore Steel Camp Mug.

Surfer, model and writer, Corinne Evans coaches female-only surf camps to introduce other women and girls to the joy of wave-riding.



Sandy Kerr.  
Scotland, UK.  
Northcore Slice Thruster Fins.

Tynemouth surfer and lifeguard,  
Sandy Kerr lives to chase barrels  
over Northern granite reefs.

Alaska, USA.  
'Kick Back' Hammock.

Kicking back in Alaska on the Northcore Rip  
stop travel hammock.

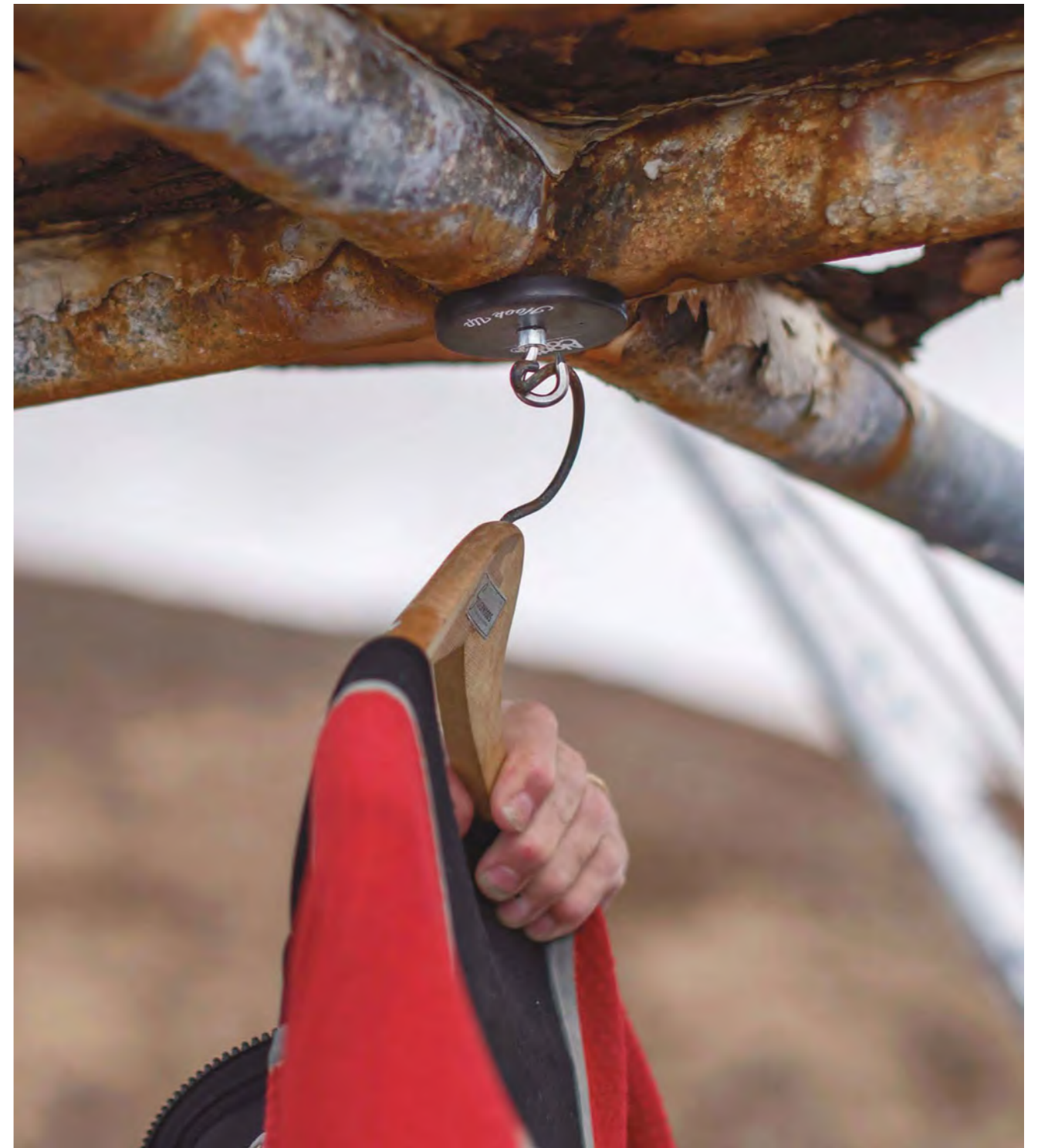

Alaska, USA.  
Northcore Travel Pack and Fins.

The Northcore Travel Pack is designed for stowing a range of surf kit.

Alaska, USA.  
Northcore Hook Up Wetsuit Hanger.

The Northcore Hook Up magnet serving its purpose on tours of the Aleutian Islands aboard an Alaskan surf trip boat.

# UNCOMMON PROMISING PRODUCTS. LAST. BUILT TO LAST.



**Beach Basha PRO - Black**  
NOCO24E



**Beach Basha PRO - Red**  
NOCO24G



**Beach Basha PRO - Blue**  
NOCO24I



**Ultimate Grip Deck Pad - White**  
NOCO63J



**Ultimate Grip Deck Pad - Blue**  
NOCO63K



**Ultimate Grip Deck Pad - Red**  
NOCO63L



**Ultimate Grip Deck Pad -  
The Rasta**  
NOCO63G



**Ultimate Grip Deck Pad -  
The Wave**  
NOCO63F



**Dry Bag - 40L**  
NOCO67



**Surf Wax Comb – Black**  
NOCO17A



**Surf Wax Comb – Red**  
NOCO17B



**Surf Wax Comb – Green**  
NOCO17C



**Surfshields Surfers Ear Plugs**  
NOCO115



**6mm Surfboard Leash  
6'0" – White**  
NOCO54A



**6mm Surfboard Leash  
7'0" – Blue**  
NOCO55C



**Bamboo Surf Wax Comb**  
NOCO17D



**Waterproof Changing Mat**  
NCM01



**Grass Change Mat/Bag**  
NOCOM02



**6mm Surfboard Leash  
8'0" – Black**  
NOCO56B



**6mm Surfboard Leash  
9'0" – Red**  
NOCO57D



**Heavy Duty Leash String**  
NOCO92C



**Lockjaw Surfboard Fin Lock**  
XL01



**Lockjaw Surfboard Travel Lock**  
XL02



**Keypod 5GS**  
XK02-5GS



**Surfboard Rack – Single**  
NOCO90A



**Surfboard Rack – Double**  
NOCO90B



**Surfboard Rack – Quad**  
NOCO90C





**Surfboard Display Sling  
- Modular**  
NOCO04C

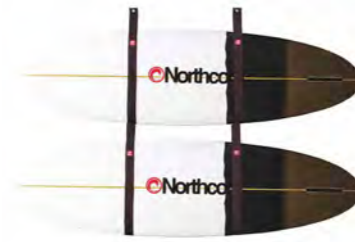

**Surfboard Display Sling  
- Double**  
NOCO04C



**GUMBALL Surfboard  
Ding Repair Putty**  
NOCO70



**Beach Basha Changing  
Robe - Black**  
NOCO24A



**Beach Basha Changing  
Robe - Grey**  
NOCO24C



**Beach Basha Changing  
Robe - Blue**  
NOCO24B



**Waterproof Wetsuit Bag**  
NOCO43



**Surfboard Sock - Longboard**  
NOCO42B



**Surfboard Sock - Shortboard**  
NOCO35



**Beach Basha Changing Robe  
- Red Stripes**  
NOCO24M



**Beach Basha Changing Robe  
- Grey Stripes**  
NOCO24L



**Beach Basha Changing Robe  
- Blue Stripes**  
NOCO24K



**Northcore Powerstroke Original**  
POW-001



**Northcore Powerstroke PRO**  
POW-002



**Waterproof Key Pouch**  
NOCO62



**Beach Basha Changing Robe  
KIDS - Blue**  
NOCO24D



**Addiction Longboard  
Surfboard Bag**  
7'6 - NOCO51B 9'6 - NOCO53B  
8'0 - NOCO52B



**Addiction Shortboard/Fish/  
Hybrid Surfboard Bag**  
6'0 - NOCO46B 6'8 - NOCO48B  
6'4 - NOCO47B 7'0 - NOCO50B



**Shortboard Day/Travel Bag**  
 6'0 - NOCO23A 7'0 - NOCO29  
 6'4 - NOCO26 7'6 - NOCO31  
 6'8 - NOCO27



**Longboard Day/Travel Bag**  
 NOCO33B



**Surfboard/SUP Carry Sling**  
 NOCO16



**Slice Futures S5 Red - Ultra Light Hex Core**  
 SLI-09D



**Slice Futures S5 Blue - Ultra Light Hex Core**  
 SLI-09E



**Slice S5 Black - Ultra Light Hex Core FCS Compatible**  
 SLI-02F



**Deluxe Surfboard/SUP Carry Sling**  
 NOCO16B



**Northcore SlideHanger**  
 NOCO110



**Wetsuit Hanger Strap**  
 NOCO111



**Slice S5 White - Ultra Light Hex Core FCS Compatible**  
 SLI-02A



**Slice S5 Green - Ultra Light Hex Core FCS Compatible**  
 SLI-02C



**Slice S5 Blue - Ultra Light Hex Core FCS Compatible**  
 SLI-02E



**The Bolt - Longboard Fin Bolt**  
 NOCO18



**Fin Bolt - Longboard Screw and Plate**  
 NH04



**Surf Straps**  
 NOCO16C



**Slice S5 Red - Ultra Light Hex Core FCS Compatible**  
 SLI-02D



**Slice S5 Yellow - Ultra Light Hex Core FCS Compatible**  
 SLI-02B



**Slice 9" Centre Fins - Red**  
 SLI-07B



**Slice 9" Centre Fins – Blue**  
SLI-07A



**Slice 8" Centre Fins – Smoke**  
SLI-06E



**Slice 8" Centre Fins – Orange**  
SLI-06D



**Desk Top Tide Clock**  
NOCO88



**Wall Mounted Tide Clock**  
NOCO88B



**Time and Tide Bamboo Wall Clock**  
NOCO88D



**Slice 8" Centre Fins – Green**  
SLI-06C



**Slice 8" Centre Fins – Red**  
SLI-06B



**Slice 7" Centre Fins – Smoke**  
SLI-05E



**Hawaiian Hula Dashboard Doll**  
NOCO91



**Soundwave Waterproof Earphones**  
NOCO181B



**Ultra Slim Wallet – Dark Brown**  
NOCO95



**Slice 7" Centre Fins - Red**  
SLI-05B



**Slice 7" Centre Fins – Blue**  
SLI-05A



**Slice FCS Compatible Fin Key**  
NH06B



**T-Bone Skate Multi Tool**  
NCSK005



**Skate Hanger**  
NCSK006



**Leather Carry Handles**  
NOCO119A



**iPhone 8 Bamboo Case:  
Adventure Division**  
NOCO122C



**iPhone 8 Bamboo Case: Wave**  
NOCO122A



**iPhone 8 Bamboo Case:  
Motorbike**  
NOCO122B



**Roof Bar Pads**  
NOCO21



**Wide Load Roof Bar Pads**  
NOCO21B



**Aero roof bar pads**  
NOCO21C



**Lanyard**  
NOCO69



**Stickers**  
Landscape: NCM-001A  
Stacked: NCM-001B



**Car Seat Cover**  
NOCO05A



**Double Van Seat Cover**  
NOCO06



**Rear Car Seat Cover**  
NOCO07



**Camo Car Seat Cover**  
NOCO05B



**Camo Double Van Seat Cover**  
NOCO06B



**Neoprene Car Seat Cover  
- Single - Black**  
NOCO05C



Hook Up Magnetic Wall Hanger  
NOCO82



Air Freshener  
Bubblegum - NOCO44  
Coconut - NOCO45



Leather Luggage Tag  
NOCO114



Moped Surfboard Carry Rack  
NOCO66



Bike Surfboard Carry Rack  
NOCO65



Viper-X Snowboard Lock 2G  
NOCO13B



D-Ring Tie Downs  
NOCO22B



Tie Downs  
NOCO22



Three Door Soft Roof Rack  
NOCO64



Waxed Canvas Backpack - Khaki  
NOCO15



Waxed Canvas Backpack - Stone  
NOCO15



Waxed Canvas Backpack - Chocolate  
NOCO15



Single Soft Roof Rack  
NOCO02



Double Soft Roof Rack  
NOCO01



D Ring Single Soft Rack  
NOCO02B



Duffel Bag - Black/Orange  
40L - NOCO123AB 85L - NOCO123BB  
110L - NOCO123CB



Duffel Bag - Black/Grey  
40L - NOCO123A 85L - NOCO123B  
110L - NOCO123C



Duffel Bag - Black/White  
40L - NOCO123AC 85L - NOCO123BC  
110L - NOCO123CC



Single Soft Roof Rack  
NOCO02



Double Soft Roof Rack  
NOCO01



D Ring Single Soft Rack  
NOCO02B



Wheeled Duffel Bag - Black/Orange  
110L - NOCO123DB



Wheeled Duffel Bag - Black/Grey  
110L - NOCO123D



Wheeled Duffel Bag - Black/White  
110L - NOCO123DC



**Hammock Daisy Chain Webbing**  
NOCO103B



**Kick Back Hammock**  
NOCO103



**Bamboo Stainless Steel  
Thermos Flask 360ml**  
NOCO97



**4oz Leather Hip Flask**  
NOCO104



**USB Head Torch**  
NOCO116



**Enamel Mug - Surf**  
NOCO86B



**Wool Blanket**  
NOCO120



**Waxed Canvas Adventure Roll**  
NOCO119



**Bamboo Stainless Steel  
Thermos Flask 360ml with Mug**  
NOCO97B



**Enamel Mug - Adventure  
Division - White**  
NOCO86C



**Enamel Mug - Adventure  
Division - Blue**  
NOCO86E



**Enamel Mug - Adventure  
Division - Green**  
NOCO86F



**Fire Piston**  
NOCO107



**Camping Pocket Knife**  
NOCO112



**Fire Steel - 4 in 1 Survival Tool**  
NOCO121



**Enamel Mug - Adventure  
Division - Red**  
NOCO86D

**NORTHCORE**  
**BRAND GUIDELINES**

**THE NORTHCORE BRAND**

**SIMPLICITY.**  
**MATURITY.**  
**FLEXIBILITY.**  
**PERSONALITY.**

Our logo is our most important asset – the brand recognition throughout all consumer touchpoints.

It is available in positive or negative forms, and should only be positioned on white, black or on an image, never on campfire orange or a secondary colour.



POSITIVE

The relationship between the logotype and icon is set and should never be altered, regardless of whether the positive or negative versions is used.

Our logo should never be altered in any way.



NEGATIVE



## EXCLUSION ZONE



An exclusion zone should be applied to the logo at all times to ensure it has stand-out. This is the equivalent of the size of the icon.

## MINIMUM SIZE

 Northcore

30mm

 Northcore

120px

Legibility of the logo must be paramount on all applications, therefore the minimum size of the logo is 30mm in width offline and 120px online.

## USING THE ICON AS A GRAPHIC

Our wave icon can be isolated for use as a large graphic on products in either red, black or white. Only use one per application.

When using the icon, the full logo should not be used as well on the same application.



## MINIMUM SIZE



10mm

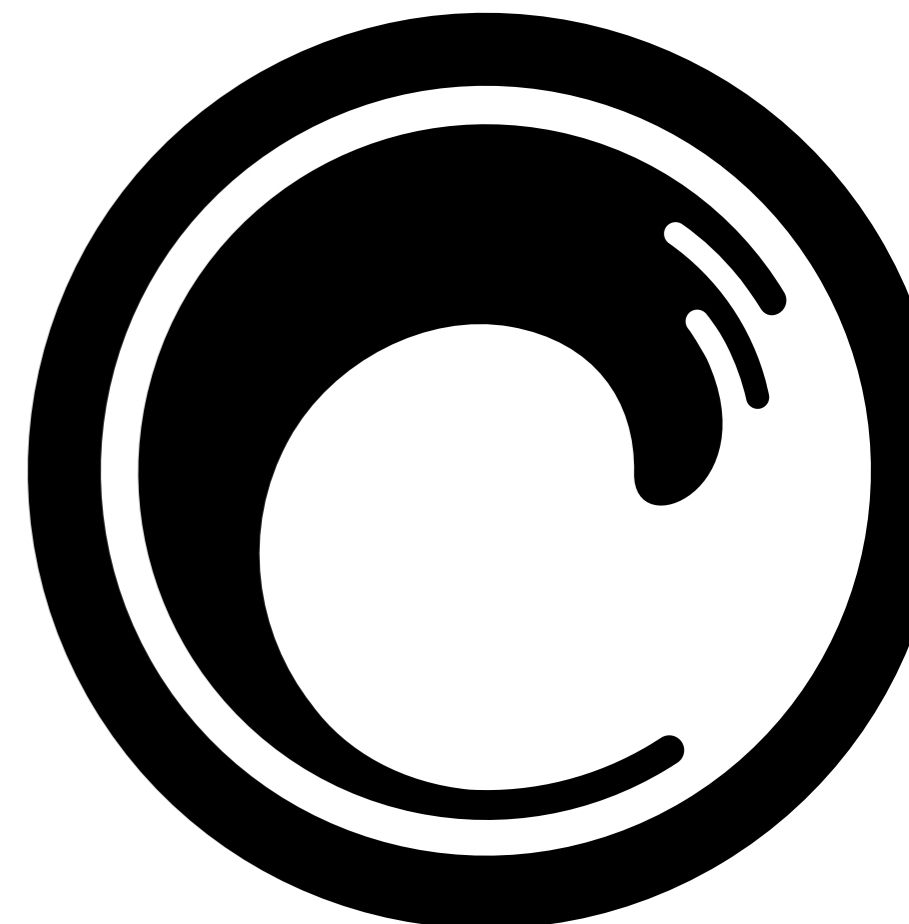

# BEBAS NEUE BOLD. FOR MAKING A STATEMENT.

## MINIMUM TYPESETTING

PT SIZE 16PT  
KERNING +75 (OPTICAL)  
LEADING +0

With its condensed and bold aesthetic, Bebas Neue Bold is ideal for headlines that need to stand-out.

Bebas is our dynamic font, meaning that the typesetting can be fluid to create interesting and surprising layouts. This page outlines only the minimum typesetting to retain legibility at all times.

Use this font for headline, pull-out information and smaller captions – across all applications.

# Tiempos Headline Semibold. For starting a conversation.

## RECOMMENDED TYPESETTING

KERNING +10 (OPTICAL)  
LEADING +5

Tiempos Headline offers a visual counterweight to Bebas. With its sense of authority and stability, it also adds a conversational personality to brand pieces.

Tiempos would be used in brand literature, like brand and look books, but it is never to be used on functional applications like products or packaging.

# Nimbus Sans Regular.

For getting the  
point across.

## RECOMMENDED BODY COPY TYPESETTING

PT SIZE	9PT
KERNING	-15 (OPTICAL)
LEADING	+4

Nimbus Sans epitomises function. Its letterforms are designed for clear legibility, even at small sizes. While the two hero fonts provide noise, energy and authority; Nimbus adds a clear functionality.

# Dynamic. Passionate.

Whether its surf or adventure focussed, the same passion and energy should be conveyed through our imagery.

Mix colour and monochromatic imagery for dynamic creative; with a greater emphasis placed on black and white photos.

Experiment to achieve dynamic layouts by multiplying imagery over one other, mixing full bleed and montages, interesting crops and placements.

However imagery is used, always look to capture the passion, energy and personality this community has and their connection to the planet.

When commissioning new photography, use different camera angles and subjects to create unique, interesting imagery.

# Real. Aspirational.



# White

C0 M0 Y0 K0  
R255 G255 B255  
#ffffff

# Black

C40 M0 Y0 K100  
Pantone Black C/U  
R0 G0 B0  
#000000

# Campfire Orange

C0 M43 Y90 K0  
Pantone 144C/U  
R246 G161 B36  
#F6A123  
Perspex A005F (Glow Edge)

C42 M11 Y32 K16  
Pantone 557C/U  
R144 G174 B162  
#90aea2

# Shallows

SURFING

# Depths

C75 M33 Y40 K75  
Pantone 7476C/330U  
R22 G55 B58  
#16373a

C15 M20 Y7 K60  
Pantone 430C/U  
R118 G112 B118  
#767076

# Mist

ADVENTURE

# Charcoal

C40 M33 Y20 K80  
Pantone 7540C/433U  
R57 G57 B63  
#39393f

# Passionate. Uncompromising. Authentic.

## Surfing isn't for the faint of heart or the fair weathered. It's for those committed to freedom and adventure.

Those who charge slabs without fear. Who battle the might of the ocean knowing they won't always win. But when they do, when they're up there, riding a mountain of water, nothing compares or even comes close. It's why they love every single minute of it.

It's this uncompromising, thrill-seeking sense of escapism that Northcore's tone of voice must reflect. It's about saying we get you because we're the same as you. We know how you feel because we feel it too. It's why we know what products you need through our own experiences.

The brand should talk peer-to-peer, using the language of the cold-water surfer and adventurer communities.

Following our core purpose, the tone of voice is passionate, uncompromising and authentic.

Through the tone of voice, we aim to make people feel inspired (to get out there), confident (in the quality of the products) and adventurous (ready to push themselves to the limit).

---

## HASHTAG.

From posts across our social channels to printed comms such as press ads, we can sign off with the following hashtag to support our brand messaging:

**#BornFromTheElements**

## PASSIONATE.

We are...  
Always ready to surf, in any conditions.  
Love what we do and why we do it.

We are not...  
Passive, timid and never take the sea for granted.

## UNCOMPROMISING.

We are...  
Dedicated. Always seeking better ways to build our products and new ways to make life easier for our customers. The restless pursuit of waves informs our work ethic.

We are not...  
Set in our ways, condescending, patronising or afraid to try new things.

## AUTHENTIC.

We are...  
Genuinely obsessed with surfing and adventure sports. We live it and love sharing our knowledge with others.

We are not...  
Playing at this. You've got to be committed. Otherwise the novelty of gearing up to surf cold water wears thin pretty quick.



## RETAIL TOOLKIT

# THE PREMIUM PACKAGE

WITH ITS BLACK POWDER COATED STEEL FRAME, REAL WOOD PANELS AND ACRYLIC DETAILING, OUR PREMIUM PACKAGE REALLY ELEVATES THE RETAIL EXPERIENCE WHILE OFFERING MORE MERCHANDISE SPACE WITHIN THE SAME FOOTPRINT.

## OPTIONS IN THE PREMIUM PACKAGE

- Free standing display unit with internal merchandise shelving and external peg and slat wall panels – shoppable from three sides.
- Counter top display unit using the same materials for a consistent premium aesthetic.



FREE STANDING DISPLAY UNIT





COUNTER TOP DISPLAY UNIT

Materials: Black powder coated steel  
Silver birch  
Black acrylic panel with cut acrylic logo

Assembly: Self-assembly

Delivery: Flat-pack

Dimensions: 550x1600x550mm

Customisation: Adjustable internal shelving  
Image options available for one printed graphic panel

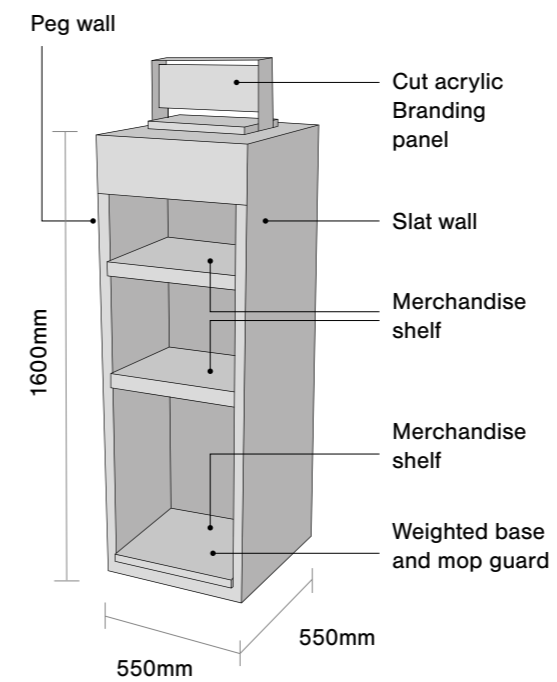

Materials: Black powder coated steel  
Silver birch  
Black acrylic panel with cut acrylic logo

Assembly: Self-assembly

Delivery: Flat-pack

Dimensions: 300x350x300mm

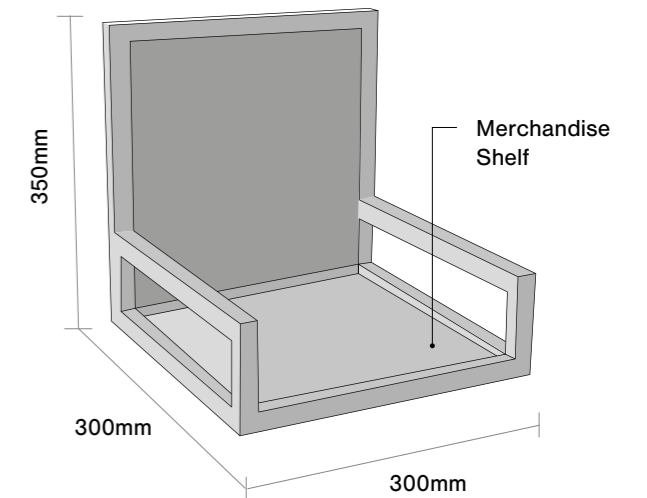

SPECIFICATIONS

# THE EXPERIENCE PACKAGE

THIS ULTIMATE SHOP-IN-SHOP IMMERSSES CUSTOMERS INTO THE NORTHCORE BRAND, WITH AN ENHANCED SHOPPING EXPERIENCE.

Building on the premium package, black power coated steel and silver birch are used to create more merchandising space.

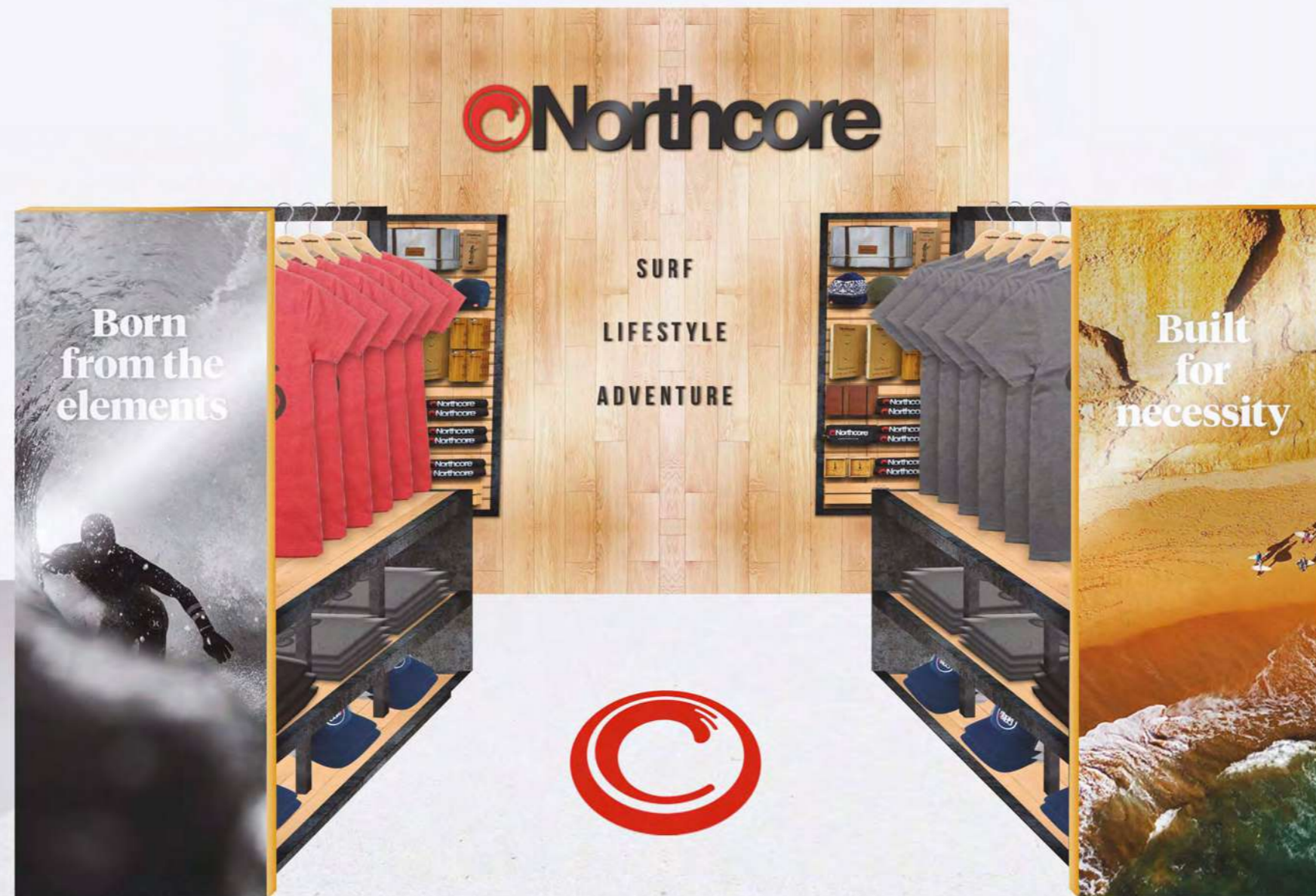

# SPECIFICATIONS

- Materials: Black powder coated steel  
Silver birch  
Cut acrylic  
Slat wall
- Assembly: Professional assembly
- Customisation: Image options available for two printed graphic panels

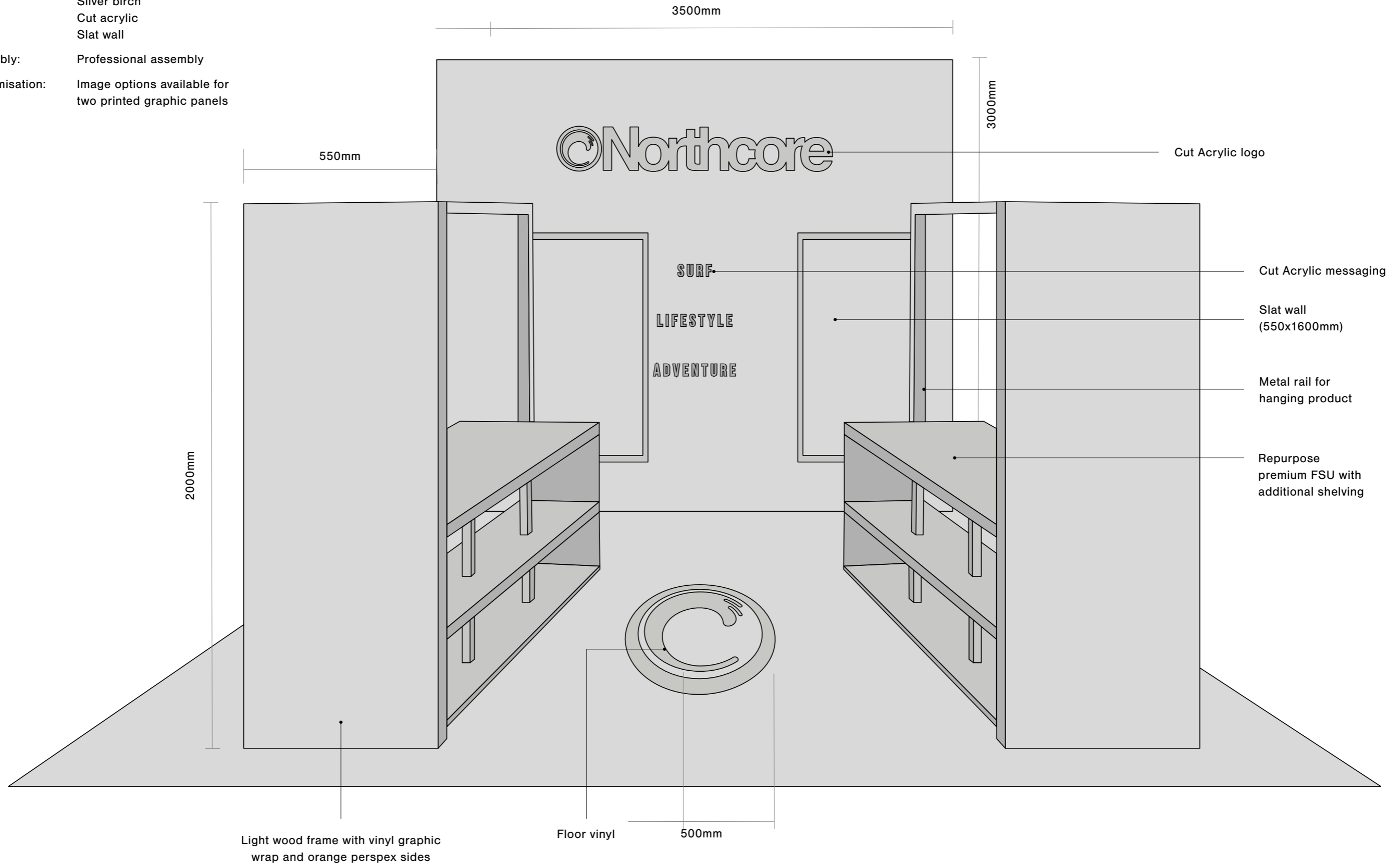

# THE SLAT WALL PACKAGE

TO UTILISE YOUR EXISTING SLAT WALL DISPLAY UNITS, WE ALSO OFFER THE OPTION OF A LARGE PRINTED ACRYLIC BRAND PANEL WITH SLAT WALL FIXTURES TO ATTACH.

THIS GIVE YOU FLEXIBILITY TO ARRANGE NORTHCORE MERCHANDISE WITHIN YOUR AVAILABLE WALL SPACE.

## SPECIFICATIONS

- Materials: Printed acrylic panel  
Vinyl print on wood panel
- Assembly: Fixings to be attached upon arrival
- Dimensions: 550x1600mm
- Customisation: Image options available for one printed graphic panel

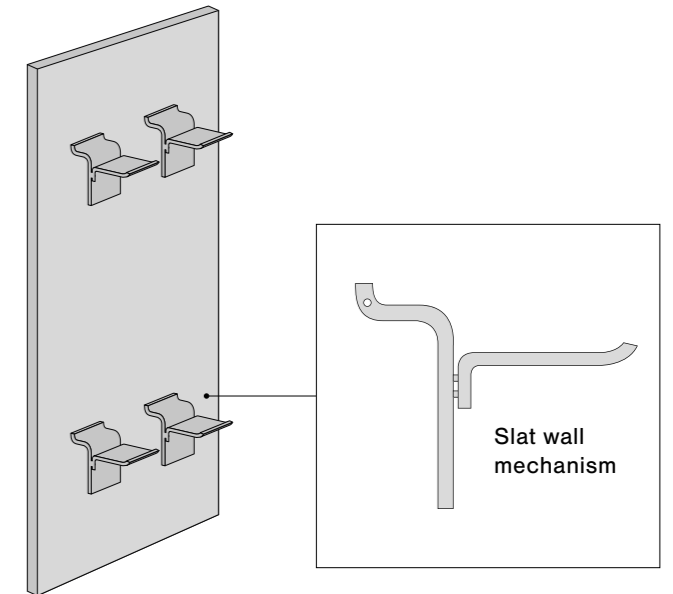

Slat wall for illustrative purposes only.

# CUSTOMISATION

We offer the opportunity to tailor your freestanding unit or slat wall panel to your clientele by providing image options from the Northcore range.

Choose from these options.



CUSTOM 1

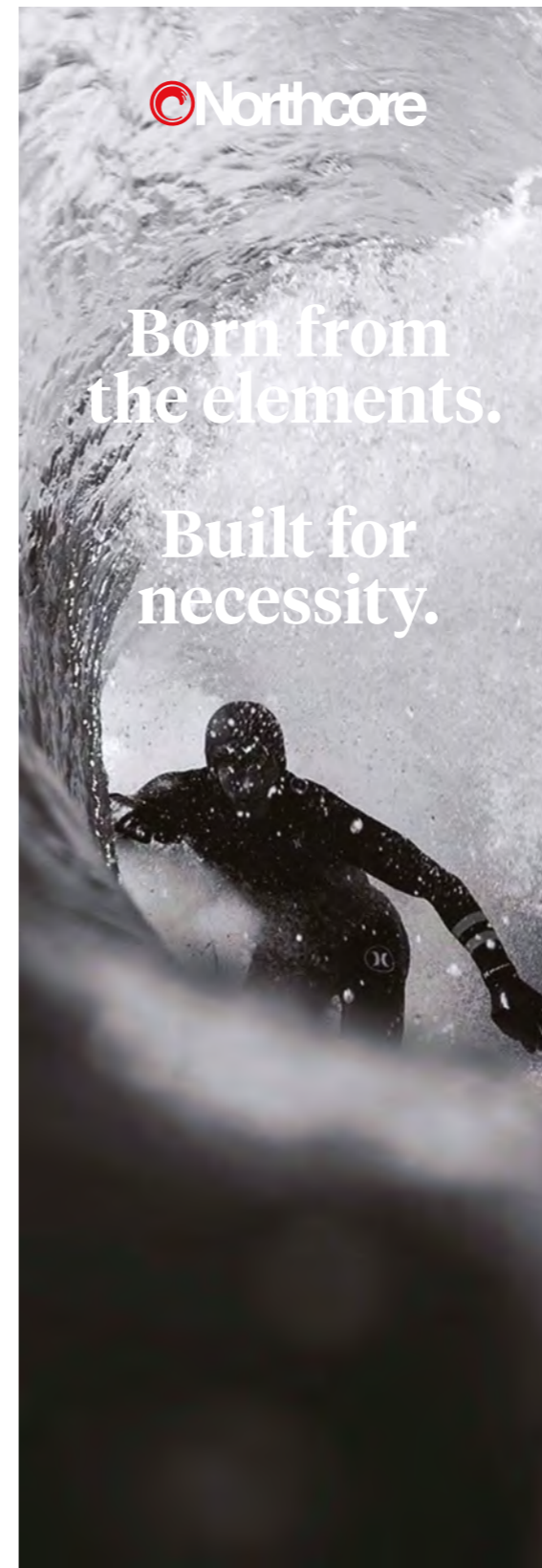

CUSTOM 2

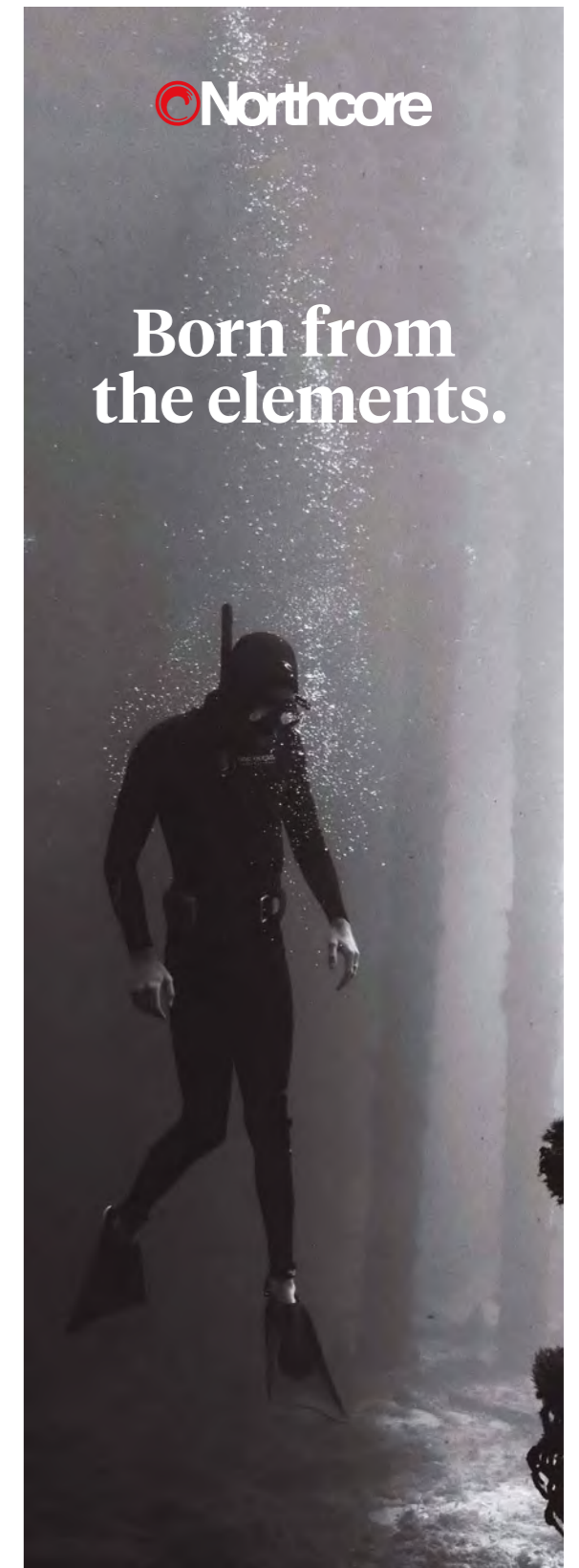

CUSTOM 3

SURF LIFESTYLE ADVENTURE

 **Northcore**

[NORTHCORE-EUROPE.COM](http://NORTHCORE-EUROPE.COM)